

## Detail Layout

# The *Best of Both Worlds*

*With our Patent Pending DC designs*

- A wide margin for a chatterless rotational stability
- A “no margin” Shaving edge for a smooth precision finish and the fastest RPM

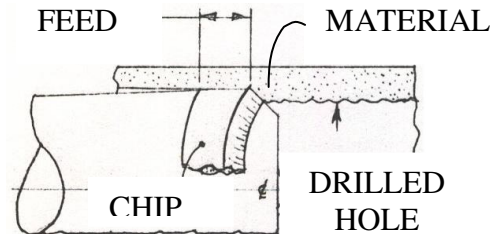
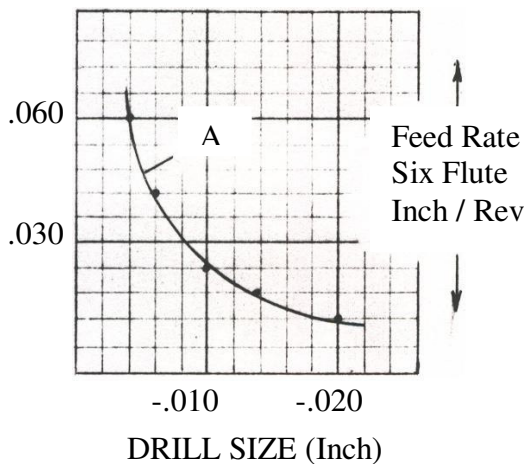
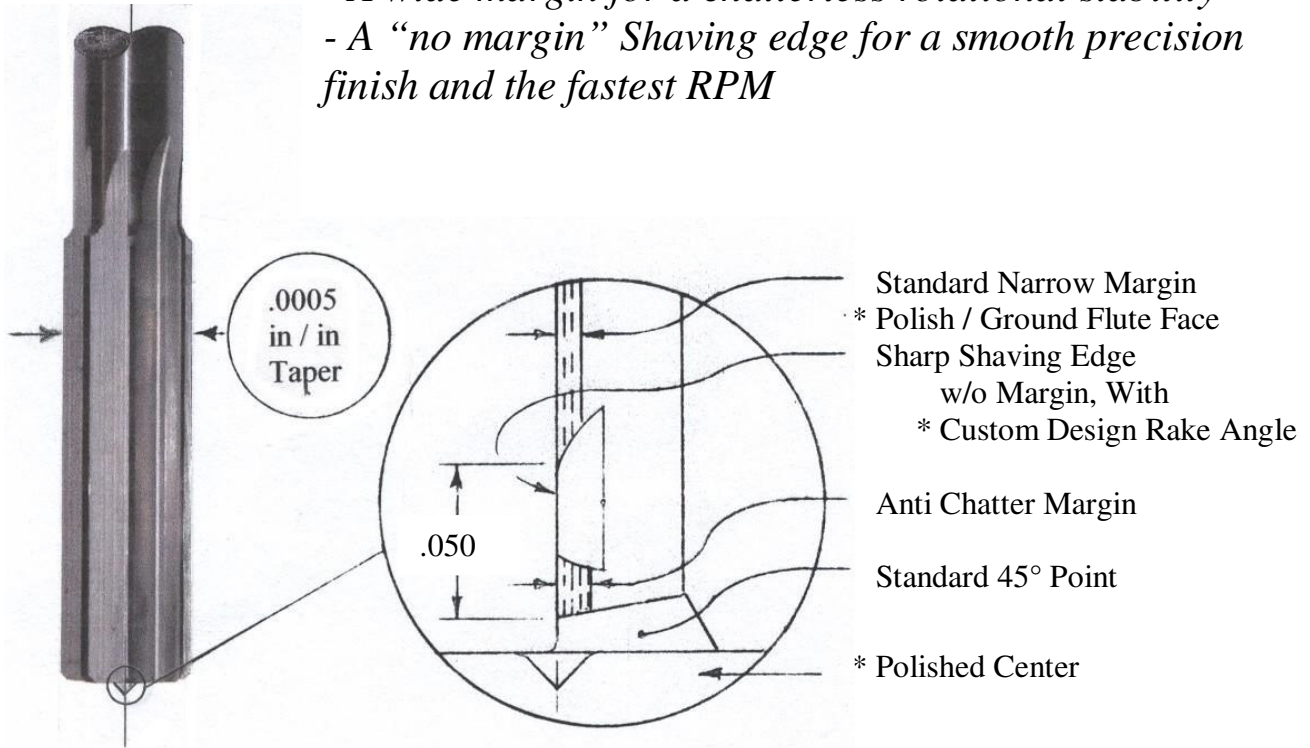

Curve A – 3/8 Reamer dia.....  
 Material.....1018 CRS  
 Lubrication...Water sol oil  
 RPM.....1700  
 Flute Face Angle...+4 degree

Type: DC Pro ; .....Hole Size +.0001/-0.0000  
 Finish ...12 Ra @ .018 in/rev  
 ...21 Ra @ .060 in/rev

\* May be omitted on DC Precision Series